

G-SERIES  
**COMPACT TRACK LOADERS**



JOHN DEERE

331G / 333G

**INTELLIGENCE  
AT WORK**







*WORKING HARD SO YOU CAN*

**WORK SMART**



INTRODUCING THE JOHN DEERE  
"G-FORCE"

**ART.**



RELIABLE

+



PRODUCTIVE





## ***YOUR INSPIRATION, OUR DEDICATION.***

You run 'em, so why wouldn't we pick your brain about your expectations of a compact track loader (CTL)? As participants in our Customer Advocate Group, users like you stepped up and helped point the way for the G-Series. Challenged and inspired by your thoughts and ideas, we went to work on Generation Next. With more power under their hoods and noticeably more lift height, dump clearance, and reach, the 331G and 333G are a big step up from our previous models.



# HEAD-TURNING PERFORMANCE

SEE WHAT YOU CAN DO.

You're going to like what you see in these new "Gs". With noticeably amped-up specs and productivity-boosting enhancements, the 97-hp 333G has what it takes to put you at the top of your game. With increased power, the 89-hp 331G isn't exactly a pushover, either. Both deliver performance that'll really grab your attention — as well as your share of the work.

## Beast mode

Superior pushing power and boom and bucket breakout forces deliver the tractive effort and leverage to carve out clay, power through piles, and handle heavy loads.

## Superior stability

6.75-in.-longer track frames increase stability and balance. Optimized roller spacing helps level moves, for increased agility and enhanced operator comfort.

## Fewer pit stops

Fluid-efficient diesels and large-capacity tanks enable daylong operation, letting you do more between fill-ups.

## Machine intelligence

New productivity-boosting electrohydraulic (EH) options include return-to-dig, return-to-carry, attachment positioning, and boom-up/down self-leveling. Push-button activated through the sealed-switch module, these settings help increase operator efficiency.

## Speedsters

Two-speed drivetrain is standard, delivering fast travel speeds up to almost eight mph, for quick work cycles.

## Generous FT4 power

Smooth-running turbocharged 3.1-L EPA Final Tier 4 (FT4)/EU Stage IV diesels meet rigid emission standards and pack plenty of power and torque reserve.

## Hydraulic boost

Increased auxiliary hydraulic flow and power enable the G-Series to make the most of an even wider variety of attachments.



**6.75-IN.-LONGER  
TRACK FRAMES**





STANDOUT FEATURE

# TALL ORDER.







# **DO MORE WITH ONE**

## **REACH HIGHER WITH LESS EFFORT.**

You said you wanted a CTL with even bigger abilities. We heard you. The 331G and 333G's refined vertical-lift loader design rises higher and reaches farther, for quicker and easier loading. Serves up substantially greater boom and bucket breakouts, too. In fact, these large frames have more horsepower than some small backhoes or crawlers, so you accomplish more with just one CTL. They also work more comfortably in tight quarters, and they're easy to trailer. Now, who says you can't always get what you want?

### **Power lifter**

Increased rated capacities of up to 3,700 lb. give these machines the muscle you need to tote heavy loads.

### **Load warrior**

Height to hinge pin is 11 ft., enabling these CTLs to easily load tandem-axle dump trucks, feed mixers, and fill hoppers. You'll also appreciate the additional six in. of truck-bed-height reach when handling pallets of pavers or other heavy materials.

### **Carry more, spill less**

Boom design keeps the load close to the machine for better stability. Low center of gravity, 35-deg. bucket rollback, and optional ride control/self-leveling also help keep buckets heaped and forks fully loaded.

### **Dig in**

Breakout force has been increased a whopping 40 percent over our previous models, to make lifting heavy loads easier. Helps heap the bucket and keep big loads coming, too. Add the new 90-in. bucket (available only for the 333G) and watch productivity soar.





# ROOM WITH A VIEW

*EASY TO SEE, EFFICIENT TO OPERATE.*

Large entryway, tightly sealed swing-out door, and generous foot- and legroom make it easy to get in, get comfortable, and get things done. Clear sightlines to the bucket corners, the edge of the tracks, and the jobsite ahead and behind instill close-quarters confidence and capability. And convenient, easy-to-operate controls make the most of an operator's skill, for a more productive day.

## Your controls, your way

Add the industry-exclusive three-way switchable controls and electro-hydraulic (EH) joystick performance package for even more operating flexibility. Push-button selectable through the sealed-switch module (SSM), this feature enables the following:

- Three-way switchable controls between EH foot, ISO joystick, or H-pattern joystick modes. Includes switchable accelerator/decelerator with right-side foot pedal when operating in ISO or H-pattern joystick-control mode.
- EH joystick performance package featuring selectable propel speeds, creeper mode, boom- and bucket-speed settings, and 12-volt three- and 14-pin attachment-control harness.

## Heads-up operation

Overhead panel conveniently places machine info on the left, control switches to the right. Easy-to-read LCD monitor provides a wealth of info and control — including vital operating conditions and advanced diagnostics.

## See even more

Sightlines to the sides and below the boom to the ground and tracks have been improved. Visibility gets even better when you add an optional rearview camera that displays the action behind on an upfront monitor.

## Lighten up

Courtesy lighting stays on after machine shutdown and then automatically turns itself off, for safe cab exits after hours and conservation of battery power. Optional LED lighting package provides unsurpassed all-around illumination. It's a "must have" for after-dark tasks such as snow removal. Or whenever you need to extend your day.

## Push-button convenience

Optional SSM controls amenities such as keyless start and anti-theft settings, plus fingertip activation of numerous machine functions including optional ride control and bucket-up self-leveling. SSM intelligently stores up to five different operator codes and sets of preferences, including boom/bucket and propel speeds, creep modes, and control patterns.

## Safety first

Like on all John Deere machines, personal-protection features abound. In-cab-activated boom lock and triple-interlock operator-presence system help keep harm's way from hijacking your day. Standard rearview mirror, horn, and backup alarm further enhance the safety of bystanders.



## Four-season comfort

Add a heated suspension seat to the heated and air-conditioned pressurized cab for productivity-enhancing year-round comfort.









## ***TOUGH ENOUGH*** ***UPTIME YOU CAN BANK ON.***

Like all John Deere machines, the G-Series is loaded with time- and money-saving features. Uptime advantages such as rugged job-proven Yanmar engines, sealed electrical connectors, O-ring face-seal hydraulic fittings, and large coolers all help keep downtime down. Plus, a standard automatic-shutdown system prevents overheating or low fluids from ruining more than just your day. When you know how they're built, you'll run a Deere.





### **Cool idea**

Unique Tri-Cool design resists debris buildup and employs large coolers for superior performance in severe, high-load conditions. Add a reversible fan for quick core cleanout in high-debris applications.

### **Heavy-duty drivetrains**

Oil-bathed final-drive chains withstand daily punishment and almost never need adjustment.

### **Beefed-up track components**

Track is longer, and rollers and idlers wider, to increase contact area. Plus, spacing has been optimized to help maximize track life.

### **Big biceps**

Large cross-section boom arms and heavy-duty upper links provide stamina and strength, for long-term endurance.

### **Anti-leak fittings**

O-ring face-seal hydraulic fittings virtually eliminate aggravating and costly oil leaks.

### **In-boom hydraulics**

Auxiliary hydraulic lines and wiring are routed through the boom where they're protected from damage.

### **Give yourself a break**

Spring-applied hydraulically released wet-disc park brake is maintenance free.

### **Sealed switches and connectors**

Switches and electrical connectors are sealed from moisture and debris, to help resist corrosion.





# ***WORK OUR CONNECTIONS.***

## ***BE ALL THINGS TO ALL PEOPLE.***

If you're looking for a way to help build your business, Worksite Pro™ attachments are a great place to start. With more than 100 models, these specialized and general-purpose additions enable you to broaden your abilities, work smarter, and accomplish even more.





#### **Bucket choices abound**

Choose from rock, multipurpose, construction, utility, and tooth buckets in varying widths and capacities. Exclusive extreme-duty 90-in. tooth, serrated, or smooth-edge bucket lets you make the most of every cycle.

#### **Grab and go**

Brush, scrap, and utility grapples employ two hydraulic-actuated dual-action tongs for superior retention of a wide variety of materials.

#### **Snow business**

Equipped with optional zig-zag-style tracks and a snow blower, snow pusher, utility blade, or angle broom, G-Series machines make quick work of cleaning up whatever winter drops your way.

#### **Streetwise**

Perfect for concrete or asphalt flatwork, our angle brooms, vibratory rollers, cold planers, hydraulic hammers, and wide variety of buckets let you hit the ground running.

#### **Landscape tools**

Landscape and nursery options include tree forks, rotary tillers, planetary augers, pallet forks, power rakes, landplanes, dozer blades, and roller levels, to list just a few.

#### **Farm hands**

For handling hay, cleaning pens, rebedding stalls, or numerous other agricultural chores — we've got the utility grapples, material/manure scrapers, pallet forks, bale spears, and buckets to get it done.



**100+ MODELS**  
OF WORKSITE PRO ATTACHMENTS



---

# WE SWEAT THE DETAILS

SO YOU DON'T HAVE TO.

## Full-tilt service

Tilt up the hood for convenient ground-level access to dipsticks, fuel- and fluid-filler necks, and filters. For wide-open drivetrain access, the operator's station swings up and out of the way in less than five minutes.

## Convenient cooler cleanout

Hinged hood and easy-to-remove side shields yield wide-open access to coolers, simplifying trash removal and core cleanout. Exclusive fan option can be set to automatically reverse to clear core-clogging buildup.

## Simplified checks

Color-coded handles and caps on conveniently positioned dipsticks and filler necks simplify checks and additions. See-through reservoirs and sight gauges reveal fuel, hydraulic oil, and windshield washer fluid levels at a glance.

## Quick changes

Spin-on remote-mounted engine oil and fuel filters allow quick no-mess changes. Extended service intervals reduce downtime for scheduled maintenance.

## Easy interior cleanout

If you're a neat freak or run a rental yard, you'll appreciate these convenience features. Just remove two plates to flush out the footwells. Cab side windows also remove easily for cleaning.





---

Get valuable insight with  
**JOHN DEERE WORKSIGHT™**

John Deere WorkSight is an exclusive suite of telematics solutions that increases uptime while lowering operating costs. At its heart, JDLink™ Ultimate machine monitoring provides real-time data and health prognostics to suggest maintenance solutions that decrease costly downtime. Remote diagnostics enable your dealer to read codes, record performance data, and even update software without a trip to the jobsite

Keep downtime down with  
**ULTIMATE UPTIME**

Ultimate Uptime, featuring John Deere WorkSight, is a customizable support solution available exclusively from your Deere dealer. This flexible offering maximizes equipment availability with standard John Deere WorkSight capabilities that can help prevent future downtime and speed repairs when needed. In addition to the base John Deere WorkSight features, our dealers work with you to build an uptime package that meets the specific needs of your machine, fleet, project, and business, including customized maintenance and repair agreements, onsite parts availability, extended warranties, fluid sampling, response-time guarantees, and more.







# 331G / 333G SPECIFICATIONS

Engine	331G	333G
Manufacturer and Model	Yanmar 4TNV94FHT	Yanmar 4TNV94FHT
Non-Road Emission Standards	EPA Final Tier 4/EU Stage IV	EPA Final Tier 4/EU Stage IV
Cylinders	4	4
Net Peak Power (SAE J1349 / ISO 9249)	66.0 kW (88.5 hp) at 2,500 rpm	72.0 kW (96.6 hp) at 2,500 rpm
Gross Rated Power (ISO 14396)	68.0 kW (91.2 hp) at 2,500 rpm	74.6 kW (100 hp) at 2,500 rpm
Peak Torque	382 Nm (281.8 ft.-lb.) at 1,700 rpm	395 Nm (291.3 ft.-lb.) at 1,700 rpm
Displacement	3.1 L (186.3 cu. in.)	3.1 L (186.3 cu. in.)
Rated Engine Speed	2,500 rpm	2,500 rpm
Torque Rise	47% at 1,700 rpm	39% at 1,700 rpm
Aspiration	Turbocharged, intercooled	Turbocharged, intercooled
Air Cleaner	Dry dual element	Dry dual element
Cooling	331G / 333G	
Fan Type	Variable-speed hydraulic drive standard / reversing fan drive optional	
Powertrain	331G	333G
Pump	Axial-piston hydrostatic	Axial-piston hydrostatic
Controls	Electrohydraulic	Electrohydraulic
Travel Speeds		
Low	8.5 km/h (5.3 mph)	8.5 km/h (5.3 mph)
High	12.6 km/h (7.8 mph)	12.6 km/h (7.8 mph)
Brakes	Integral, automatic, spring-applied, hydraulically released wet-disc brake	
Undercarriage	New-Generation smooth-ride long-life rubber with steel inserts	
Rubber Tracks	New-Generation smooth-ride long-life rubber with steel inserts	
Track Width		
Standard	400 mm (15.8 in.)	450 mm (17.7 in.)
Optional	450 mm (17.7 in.)	400 mm (15.8 in.)
Ground Pressure		
400-mm (15.8 in.) Track (standard on 331G / optional on 333G)	38.1 kPa (5.5 psi)	38.4 kPa (5.6 psi)
450-mm (17.7 in.) Track (optional on 331G / standard on 333G)	33.9 kPa (4.9 psi)	34.1 kPa (5.0 psi)
Track Rollers (per side)	5 triple-flange smooth-ride all-steel rollers	5 triple-flange smooth-ride all-steel rollers
Track Idlers (per side)	2 double-flange smooth-ride all-steel rollers	2 double-flange smooth-ride all-steel rollers
Bearings/Seals (rollers/idlers)	Heavy-duty journal bearings and metal face seals	Heavy-duty journal bearings and metal face seals
Tractive Effort	5221 kgf (11,500 lbf)	5221 kgf (11,500 lbf)
Hydraulics	331G / 333G	
Pump Flow		
Standard	80 L/m (23.5 gpm)	95 L/m (25.0 gpm)
Total with High-Flow Option	138 L/m (36.5 gpm)	156 L/m (41.1 gpm)
System Pressure at Couplers	23 787 kPa (3,450 psi)	23 787 kPa (3,450 psi)
Hydraulic Horsepower Flow (calculated)		
Standard	35 kW (47 hp)	38 kW (50 hp)
High	55 kW (74 hp)	62 kW (83 hp)
Cylinders	331G / 333G	
Type	John Deere heat-treated, chrome-plated, polished cylinder rods, hardened steel (replaceable bushings) pivot pins	
Electrical	331G / 333G	
Voltage	12 volt	
Battery Capacity	925 CCA	
Alternator Rating	90 amp	
Lights	Halogen: 2 front and 1 rear standard / deluxe LED: 4 front and 1 rear optional	
Operator's Station	331G / 333G	
	ROPS (ISO 3471) / FOPS (ISO 3449) structure with quick-pivot standard	



# 331G / 333G SPECIFICATIONS



Serviceability	331G / 333G	
<b>Refill Capacity</b>		
Fuel Tank	114 L (30 gal.)	
<b>Operating Weight</b>	<b>331G</b>	<b>333G</b>
With Standard 400-mm (15.8 in.) Track	5403 kg (11,900 lb.)	—
With Standard 450-mm (17.7 in.) Track	—	5493 kg (12,100 lb.)
<b>Machine Dimensions</b>	<b>331G / 333G</b>	
<b>A</b> Length without Bucket	3.10 m (122 in.) (10 ft. 2 in.)	
<b>B</b> Length		
With Foundry Bucket	3.71 m (146 in.) (12 ft. 2 in.)	
With Heavy-Duty Construction Bucket	3.96 m (155.9 in.) (13 ft. 0 in.)	
<b>C</b> Width without Bucket		
With 400-mm (15.8 in.) Track	2.00 m (78.9 in.) (6 ft. 7 in.)	
With 450-mm (17.7 in.) Track	2.05 m (80.7 in.) (6 ft. 9 in.)	
<b>D</b> Height to Top of ROPS	2.20 m (86.7 in.) (7 ft. 3 in.)	
<b>E</b> Height to Hinge Pin	3.35 m (132 in.) (11 ft. 0 in.)	
<b>F</b> Dump Height		
With Foundry Bucket	2.69 m (106.1 in.) (8 ft. 10 in.)	
With Heavy-Duty Construction Bucket	2.50 m (98.6 in.) (8 ft. 3 in.)	
<b>G</b> Dump Reach		
With Foundry Bucket	0.71 m (28 in.)	
With Construction Bucket	0.88 m (34.6 in.)	
<b>H</b> Ground Clearance	0.24 m (9.4 in.)	
<b>I</b> Angle of Departure	31 deg.	
<b>J</b> Front Turn Radius with Foundry Bucket	2.18 m (85.7 in.) (7 ft. 2 in.)	
<b>K</b> Dump Angle (full lift height)	48 deg.	
<b>L</b> Bucket Rollback (ground level)	35 deg.	

## 331G / 333G COMPACT TRACK LOADERS

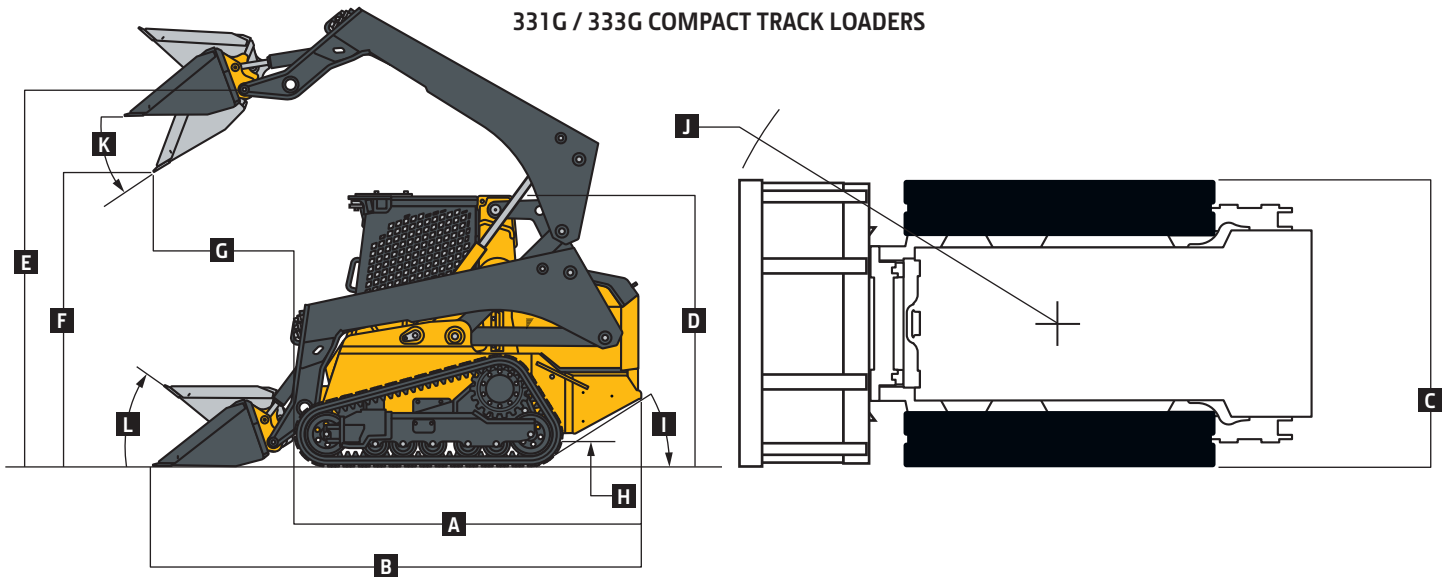

Loader Performance	331G	333G
Tipping Load	4021 kg (8,857 lb.)	4799 kg (10,570 lb.)
SAE Rated Operating Capacity at 35% Tipping Load	1407 kg (3,100 lb.)	1680 kg (3,700 lb.)
<b>Breakout Force</b>		
With Heavy-Duty Construction Bucket		
Boom	2724 kg (6,000 lb.)	3519 kg (7,750 lb.)
Bucket	3450 kg (7,600 lb.)	4200 kg (9,250 lb.)
With Foundry Bucket		
Boom	3175 kg (7,000 lb.)	3865 kg (8,520 lb.)
Bucket	4241 kg (9,350 lb.)	6307 kg (13,904 lb.)



# Additional equipment

Key: ● Standard ▲ Optional or special See your John Deere dealer for further information.

331G	333G	Engine
●	●	Meets EPA Final Tier 4/EU Stage IV emissions
●	●	Yanmar 4TNV94FHT
●	●	Auto-idle
●	●	Automatic fan tensioner
●	●	Automatic preheat
●	●	Electronic injection system
▲	▲	Engine air precleaner kit
●	●	Fuel tank, 114 L (30 gal.)
●	●	John Deere COOL-GARD™ II Extended-Life Engine Coolant
●	●	John Deere Plus-50™ 10w30 initial engine oil fill*
●	●	4-cylinder 68.0-kW (91.2 hp) 3.1-L (186.3 cu. in.) displacement
●	●	4-cylinder 74.6-kW (100 hp) 3.1-L (186.3 cu. in.) displacement
●	●	5-micron primary fuel filter and water separator
▲	▲	Cold-weather starting package
<b>Cooling System</b>		
●	●	Coolant surge tank
●	●	Variable-speed hydraulically driven fan cooling system
▲	▲	Reversing fan drive
<b>Powertrain</b>		
●	●	High-torque heavy-duty planetary-reduction final drive
●	●	Automatic spring-applied hydraulically released wet-disc park brake
●	●	Wet-disc brakes
●	●	Transmission, 2 speed

331G	333G	Hydraulic System
●	●	John Deere hydraulic cylinders with cushioned boom cylinders
●	●	John Deere heat-treated, chrome-plated cylinder rods with replaceable bushings
●	●	Connect-under-pressure auxiliary couplers
●	●	Quick-check hydraulic fluid-level sight glass
●	●	1,000-hour, 5-micron hydraulic filter
▲	▲	High-flow hydraulics
●	●	Axial-piston hydrostatic pump
<b>Electrical</b>		
●	●	Automatic engine/hydraulic shutdown protection system
●	●	Auxiliary hydraulics operator-presence system
●	●	Courtesy lighting
●	●	Deluxe instrumentation EMU with: Operator-selectable monitoring – Hour meter, engine rpm, battery voltage, diagnostics, EMU configuration, engine coolant temperature, hydraulic oil temperature / LED warning indicators – Glow plug, seat switch, seat belt, door open, auxiliary hydraulics, park brake engaged, 2-speed engaged, stop, low engine oil pressure, engine coolant over-temperature, battery not charging, air filter restriction, and hydraulic filter restriction
▲	▲	Deluxe LED lighting package with additional cab-integrated side lights (2)
●	●	Front and rear halogen work lights
●	●	Triple-interlock operator-presence control system
●	●	Backup alarm
●	●	Battery, 925 CCA
●	●	Horn
▲	▲	Hazard warning lights
▲	▲	Strobe light, amber

\*500-hour engine oil-change intervals when John Deere Plus-50 oil and John Deere oil filter are used.

Net engine power is with standard equipment including air cleaner, exhaust system, alternator, and cooling fan, at standard conditions per SAE J1349 and DIN 6270B, using No. 2-D fuel at 35 API gravity. Gross power is without cooling fan. Specifications and design subject to change without notice. Wherever applicable, specifications are in accordance with SAE standards. Except where otherwise noted, these specifications are based on units with standard equipment, full fuel tanks, and 79-kg (175-lb.) operator.



# Additional equipment *(continued)*

Key: ● Standard ▲ Optional or special See your John Deere dealer for further information.

331G	333G	Operator's Station
●	●	Deluxe cab headliner
●	●	Electrohydraulic (EH) ISO-pattern joystick controls
▲	▲	EH 3-way switchable ISO-H-foot and hand controls including joystick performance package: Switchable accelerator/decelerator, selectable propel speeds, creeper mode, boom- and bucket-speed settings, and 12-volt 3- and 14-pin attachment-control harness
▲	▲	EH ISO-H switchable controls and joystick performance package: Switchable accelerator/decelerator, selectable propel speeds, creeper mode, boom- and bucket-speed settings, and 12-volt 3- and 14-pin attachment-control harness
●	●	Keyless-start sealed-switch module with integrated anti-theft system and operator memory preference settings
●	●	Electronic push-button auxiliary controls
●	●	Pull-down adjustable lap bar
●	●	Quick-pivot ROPS
●	●	Rear window
●	●	Removable top window
▲	▲	Sliding/locking/removable glass side windows
●	●	ROPS/FOPS operator structure
▲	▲	Glass cab enclosure
●	●	Seat belt, 51 mm (2 in.), retractable
▲	▲	Shoulder belt, 51 mm (2 in.) or 76 mm (3 in.)
▲	▲	Severe-duty cab door and wiper system
●	●	Water-shedding deluxe vinyl suspension seat
▲	▲	Air-ride cloth, heated seat
▲	▲	Air-ride vinyl seat
●	●	12-volt power port / Dome light / Cargo storage / Beverage holder

331G	333G	Operator's Station <i>(continued)</i>
▲	▲	Air conditioning with heater/defroster
▲	▲	AM/FM/Weather-Band (WB) radio with auxiliary input and Bluetooth® for audio streaming
▲	▲	Floor mat with left footrest
●	●	Rearview mirror
▲	▲	Rearview camera
		Loader
●	●	In-cab boom lockout to secure loader before exiting seat
●	●	Patented John Deere Quik-Tatch™ (no grease required)
▲	▲	Power Quik-Tatch
●	●	Patented John Deere vertical-lift boom
▲	▲	Hydraulic self-leveling on/off
▲	▲	Hydraulic self-leveling on/off and ride control
		Other
●	●	Convenient front and rear tie-downs
●	●	Environmental drains for all fluid reservoirs
▲	▲	Battery disconnect
▲	▲	Chrome exhaust stack
▲	▲	Engine oil/hydraulic fluid-sampling kit
▲	▲	Forestry protection packages
▲	▲	Heavy-duty rear grille
▲	▲	Rear counterweights (available in sets of 1, 2, or 3), 78 kg (172 lb.) (each set)
▲	▲	Single-point lift kit
▲	▲	SMV sign kit
●	▲	Track, 400-mm (15.8 in.) wide
▲	●	Track, 450-mm (17.7 in.) wide
▲	▲	JDLINK™ Ultimate wireless communication system (available in specific countries; see your dealer for details)

Net engine power is with standard equipment including air cleaner, exhaust system, alternator, and cooling fan, at standard conditions per SAE J1349 and DIN 6270B, using No. 2-D fuel at 35 API gravity. Gross power is without cooling fan. Specifications and design subject to change without notice. Wherever applicable, specifications are in accordance with SAE standards. Except where otherwise noted, these specifications are based on units with standard equipment, full fuel tanks, and 79-kg (175-lb.) operator.



BUILDING. TOGETHER.



MOVING FORWARD.

**TOGETHER.**

NO TWO JOBS ARE THE SAME. And only the most versatile and dependable equipment can keep you moving forward every day. John Deere G-Series Compact Track Loaders are purpose-built with your exact needs in mind. So whether you're moving pallets or hauling rock — or anything in between — you can count on your G-Series machine to be exactly what you need it to be.



**JOHN DEERE**

[JohnDeere.com/LiftLarge](http://JohnDeere.com/LiftLarge)



DKAGCTLL Litho in U.S.A. (16-08)